



GEARex®
All-steel gear couplings

Made for Motion

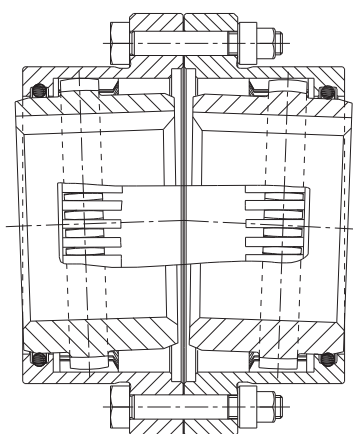

Table of contents



GEARex®	107
All-steel gear coupling	
Operating description	109
Coupling selection	110
Type FA, type FB and type FAB	111
Type DA, type DB and type DAB	112
Type FH and type DH	113
Displacements	114
Flange dimensions	115

Operating description



GEARex® couplings made from steel with grease lubrication and toroidal sealing ring correspond to the international standard. Being flexible shaft connections they are suitable for a positive torque transmission. In addition, they ensure to compensate for axial, radial and angular shaft displacements.

GEARex® couplings are used in every range of general engineering requesting for high operating safety and a long service life resulting from the reliable grease lubrication of the crowned spline. The couplings are suitable for horizontal assembly. As special solutions they are suitable for vertical assembly, too.

Numerous coupling sizes for a torque transmission from 930 Nm to 135.000 Nm with shaft dimensions up to a maximum of Ø 276 mm are available. The coupling torques may be increased by using special materials.

GEARex® couplings are in correspondence with the AGMA standard (American Gear Manufacturer Association). Small dimensions and a low weight along with a small mass moment of inertia result in a wide range of applications of GEARex® couplings.

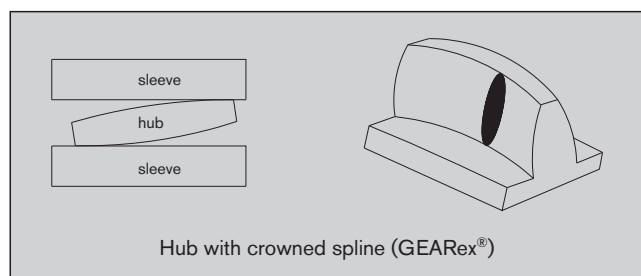

According to the operating principle of the well-known crowned gear edge pressure in the spline is avoided in case of angular and radial displacements. Moreover, permanent grease lubrication produces a better friction ratio of the spline with an operation almost free from wear along with a long service life of the coupling.

In order to ensure a regular and verified lubrication in assembled condition, two connections for hydraulics are arranged opposite to each other radially on each coupling sleeve. As a result a complete GEARex® coupling has four connections being offset to each other by 90°.

The interior of the coupling is sealed by means of toroidal sealing rings (NBR 70 ShA).

The feather keys have to be sealed against escape of lubricants during the assembly.

Explosion-proof use

GEARex® couplings are suitable for power transmission in drives in hazardous areas. The couplings are certified and confirmed according to EC standard 94/9/EC (ATEX 95) as units of category 2G/2D and thus suitable for the use in hazardous areas of zone 1, 2, 21 and 22. Please read through our information included in the respective Type Examination Certificate and the operating and mounting instructions at www.ktr.com.



Coupling selection

The coupling has to be dimensioned in a way that the permissible coupling load is not exceeded during any operating condition. For that purpose the loads that are produced have to be compared to the permissible characteristic figures of the coupling.

1 Coupling selection

The coupling is selected according to the rated torque (T_{KN}). For that purpose the corresponding operating factors of the driving machine have to be taken into account, see starting factor S_Z and operating factor S_B .

2 Load of the coupling

$$T_{KN} \geq T_{NS}$$

$$T_{NS} = T_N \cdot S_Z \cdot S_B$$

$$T_N [\text{Nm}] = 9550 \cdot \frac{P_{AN/LN} [\text{kW}]}{n [\text{rpm}]}$$

T_{KN} = rated torque of the coupling

T_N = driving torque

T_{NS} = driving torque including operating factors

S_Z = starting factor

S_B = operating factor

3 Starting torque

The permissible starting torque of the machine should not exceed two times the rated torque of the coupling.

4 Permissible load on the feather key of the coupling

The shaft-hub-connection should be verified by the customer. Permissible surface pressure according to DIN 6892 (method C).

5 Permissible temperature range

The coupling can be used in a temperature range from -20 °C to +80 °C.

6 Example of selection

Electric motor: 30 kW
Application: textile machine
Shaft-Ø: 70/65 mm
Speed: 250 rpm
Starts: < 10/h
Starting torque: $2,5 \cdot T_{KN}$

Result:

$$T_N = 9550 \cdot \frac{30 \text{ kW}}{250 \text{ rpm}}$$

$$T_N = 1146 \text{ Nm}$$

$$T_{NS} = 1146 \text{ Nm} \cdot 1 \cdot 1,25$$

$$T_{NS} = 1432,5 \text{ Nm}$$

Coupling selected:

GEARex® 15 ($T_{KN} = 2000 \text{ Nm}$)

The starting torque of the machine is 2,5 times the starting torque (3581 Nm).

(permissible $2 \cdot T_{KN} = 4000 \text{ Nm}$)

Service factor S_Z for starting frequency

starting frequency/h	10	25	50
S_Z	1,0	1,2	1,4

Operating factor S_B

Kind of load	Operating features	Machines	Operating factor
Smooth/ smoothly	Permanent operation without overload or shock load. Low connecting frequency.	<ul style="list-style-type: none"> Electric generators Radial pumps Light-weight fans 	1,00
Light-weight	Permanent operation with small overload and short-term and rare shock load.	<ul style="list-style-type: none"> Multistage radial compressors Piston pumps Large fans (heavy load operation) Mixers for liquids Mixers for solid matters Textile machines Machine tools Belt conveyor Elevators 	1,25
Average	Interrupted operation with low shock load and short-term average overload.	<ul style="list-style-type: none"> Piston compressor, cranes (running or drawing operation) Winding engine, calenders for rubber and nylon Calenders Rolling mill drives Non-reversing cold rolling mills 	1,50
Heavy	Operation with heavy and frequent shock load. Frequent load reversion. High degree of safety.	<ul style="list-style-type: none"> Bridge cranes for steel industry Mixers for rubber and nylon Cranes (heavy load operation) Wood grinders, marine drives Equipment for transport of persons Mine fans Roller tables Non-reversing cold rolling mills Reversing cold rolling mills Hot-rolling mill 	2,00
Very heavy	Extreme and overload with frequent and sudden load revolution.	<ul style="list-style-type: none"> Reversing rolling mill drives Heavy load operation in steel industry Slitting machines Grinding machines Scissors and cutters Crushers 	2,50

Type FA, type FB and type FAB



- Double-cardanic crowned gear coupling
- To be used on all applications in general engineering
- Compensating for shaft misalignment axial – radial – angular
- Available with finish bore to ISO fit H7, feather key according to DIN 6885 sheet 1, taper and inch bores
- For horizontal assembly
- Higher torques to be realized by special materials
- Approved according to EC Standard 94/9/EC (Explosion Certificate ATEX 95)

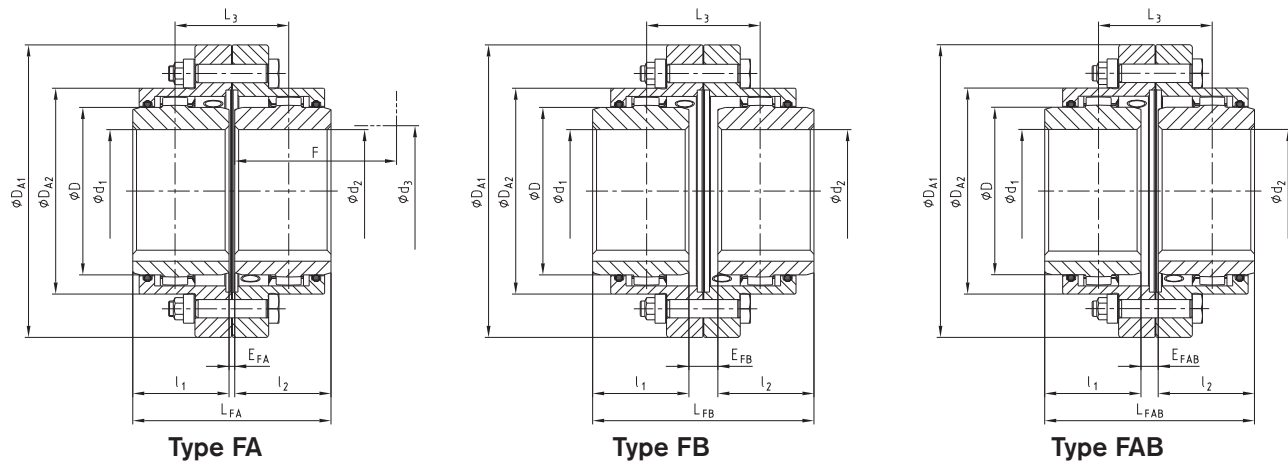

Dimensions																	
Size	Pilot bored	Max. finish bore	Dimensions [mm]													Grease ²⁾ feeding [dm ³]	
			d_1, d_2	l_1, l_2	E_{FA}	E_{FB}	E_{FAB}	L_{FA}	L_{FB}	L_{FAB}	L_3	D	D_{A1}	D_{A2}	F ¹⁾		d_3 ¹⁾
10	26	50	43	3	21	12	89	107	98	55	67	111	84	74	52	0,02	
15	26	64	50	3	15	9	103	115	109	59	87	152	107	84	68	0,04	
20	31	80	62	3	31	17	127	155	141	79	108	178	130	104	85	0,08	
25	38	98	76	5	29	17	157	181	169	93	130	213	158	123	110	0,12	
30	44,5	112	90	5	33	19	185	213	199	109	153	240	182	148	130	0,18	
35	46	133	105	6	40	23	216	250	233	128	180	280	214	172	150	0,22	
40	52	158	120	6	42	24	246	282	264	144	214	318	250	192	175	0,35	
45	80	172	135	8	50	29	278	320	299	164	233	347	274	216	190	0,45	
50	80	192	150	8	56	32	308	356	332	182	260	390	309	241	220	0,70	
55	90	210	175	8	70	39	358	420	389	214	283	425,5	334	275	250	0,90	
60	100	232	190	8	84	46	388	464	426	236	312	457	365,5	316	265	1,15	
70	100	276	220	10	76	43	450	516	483	263	371	527	425	360	300	1,50	

¹⁾ Required space to align the coupling or replace the sealing ring, respectively.

²⁾ Grease feeding for each coupling half

Technical data										
Size	Torque [Nm]		Max. speed [rpm]	Weight with max. bore-Ø [kg]			Massmoment of inertia J with max. bore-Ø [kgm ²]	Dowel screws (10.9)		
	T_{KN}	$T_{Kmax.}$		Sleeve	Hub	Total		z	M	T_A [Nm]
10	930	1860	8500	0,748	0,553	2,73	0,00436	6	M6	15
15	2000	4000	7700	1,878	1,119	6,38	0,01894	8	M8	36
20	3500	7000	6900	2,602	2,089	9,94	0,04000	6	M10	72
25	6500	13000	6200	4,432	3,564	16,83	0,09749	6	M12	125
30	10000	20000	5800	5,829	6,184	25,21	0,18080	8	M12	125
35	17000	34000	5100	9,705	9,868	41,25	0,41419	8	M14	200
40	28500	57000	4500	11,883	16,065	58,14	0,75535	8	M14	200
45	37000	74000	4000	15,724	21,419	77,08	1,17590	10	M14	200
50	51000	102000	3750	25,661	29,594	114,40	2,24991	8	M18	430
55	65000	130000	3550	31,522	40,304	150,41	3,45102	14	M18	430
60	85000	170000	3400	32,822	52,960	177,44	4,16734	14	M18	430
70	135000	270000	3200	43,521	85,768	268,20	9,32429	16	M20	610

Order form:	GEARex® FA 10	d_1 Ø 50	d_2 Ø 50
	Size and type of coupling	Finish bore keyway DIN 6885 sheet 1	Finish bore keyway DIN 6885 sheet 1

Type DA, type DB and type DAB

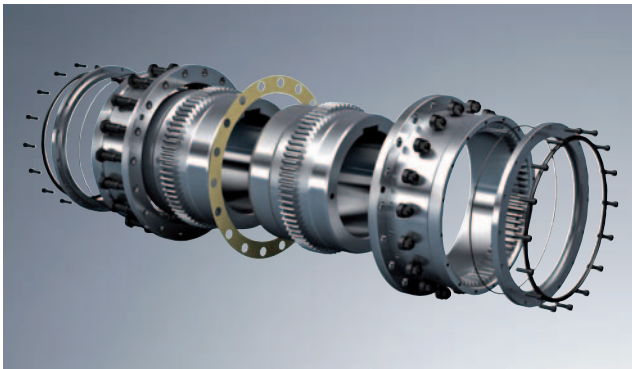

- Double-cardanic crowned gear coupling
- To be used on all applications in general engineering
- Compensating for shaft misalignment axial – radial – angular
- Available with finish bore to ISO fit H7, feather key according to DIN 6885 sheet 1, taper and inch bores
- For horizontal assembly
- Higher torques to be realized by special materials

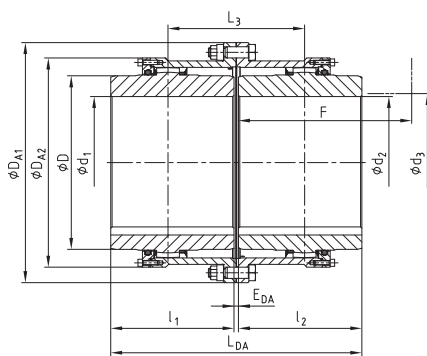

Type DA

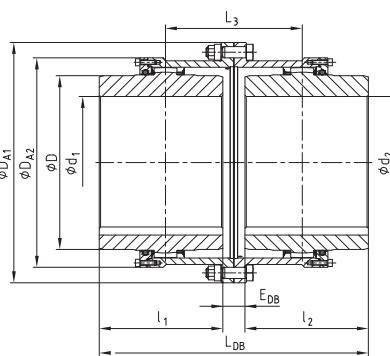

Type DB

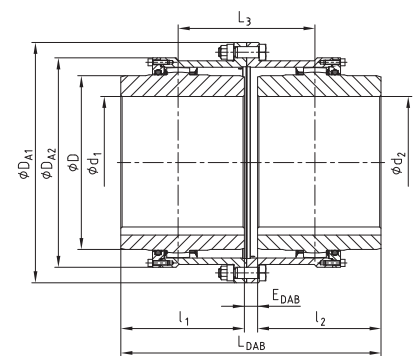

Type DAB

Dimensions																
Size	Pilot bored	Max. finish bore	Dimensions [mm]													Grease ²⁾ feeding [dm ³]
			d ₁ ; d ₂	l ₁ , l ₂	E _{DA}	E _{DB}	E _{DAB}	L _{DA}	L _{DB}	L _{DAB}	L ₃	D	DA ₁	DA ₂	F ¹⁾	
80	140	300	280	10	50	30	570	610	590	310	394	545	475	340	310	6,5
85	160	325	292	13	53	33	597	637	617	325	430	585	515	352	330	7,5
90	180	350	305	13	83	48	623	693	658	353	464	640	560	365	360	11
100	220	390	330	13	93	53	673	753	713	383	512	690	612	390	400	12

¹⁾ Required space to align the coupling or replace the sealing ring, respectively.

²⁾ Grease feeding for each coupling half

Technical data										
Size	Torque [Nm]		Max. speed [rpm]	Weight with max. bore-Ø [kg]			Massmoment of inertia J with max. bore-Ø [kgm ²]	Dowel screws (10.9)		
	T _{KN}	T _{Kmax.}		Sleeve	Hub	Total		z	M	T _A [Nm]
80	175000	350000	1900	64	117	362	14,214	18	M20	610
85	225000	450000	1800	75	148	446	20,320	20	M20	610
90	380000	760000	1500	101	183	568	31,036	20	M24	1000
100	500000	1000000	1400	117	232	698	45,358	24	M24	1000

Order form:	GEARex® DA 80	d ₁ Ø 300	d ₂ Ø 300
	Size and type of coupling	Finish bore keyway DIN 6885 sheet 1	Finish bore keyway DIN 6885 sheet 1

Type FH and type DH

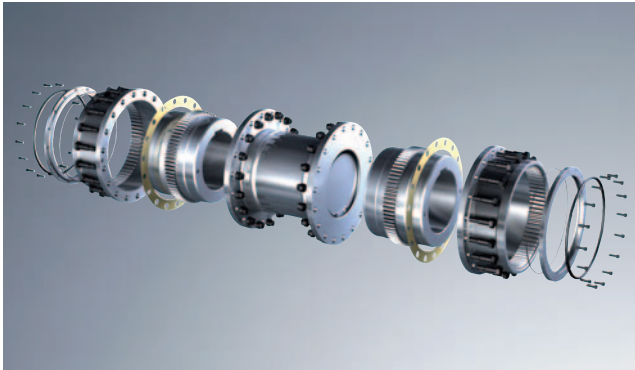

- Coupling type for bigger shaft distance dimensions
- Type FH with single-parted sleeve GEARex® size 10 to 70
- Type DH with slit sleeve GEARex® size 80 to 100
- Higher torques to be realized by special materials
- Available with finish bore to ISO fit H7, feather key according to DIN 6885 sheet 1, taper and inch bores

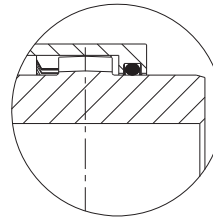
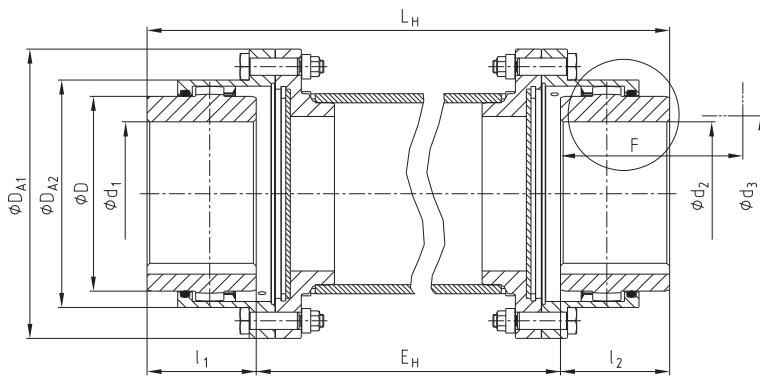

Type FH

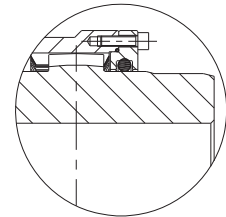

Type DH

Dimensions																
Size	Torque [Nm]		Pilot bored	Max. finish bore	Dimensions [mm]							Dowel screws (10.9)			Grease ²⁾ feeding [dm ³]	
	T _{KN}	T _{Kmax.}			d ₁ ; d ₂	l ₁ , l ₂	D	DA1	DA2	L _H	E _H	F ¹⁾	d ₃ ¹⁾	z		M
10	930	1860	26	50	43	67	111	84			74	52	6	M6	15	0,02
15	2000	4000	26	64	50	87	152	107			84	68	8	M8	36	0,04
20	3500	7000	31	80	62	108	178	130			104	85	6	M10	72	0,08
25	6500	13000	38	98	76	130	213	158			123	110	6	M12	125	0,12
30	10000	20000	44,5	112	90	153	240	182			148	130	8	M12	125	0,18
35	17000	34000	46	133	105	180	280	214			172	150	8	M14	200	0,22
40	28500	57000	52	158	120	214	318	250			192	175	8	M14	200	0,35
45	37000	74000	80	172	135	233	347	274			216	190	10	M14	200	0,45
50	51000	102000	80	192	150	260	390	309			241	220	8	M18	430	0,70
55	65000	130000	90	210	175	283	425,5	334			275	250	14	M18	430	0,90
60	85000	170000	100	232	190	312	457	365,5			316	265	14	M18	430	1,15
70	135000	270000	100	276	220	371	527	425			360	300	16	M20	610	1,50
80	175000	350000	140	300	280	394	545	475			340	310	18	M20	610	6,5
85	225000	450000	160	325	292	430	585	515			352	330	20	M20	610	7,5
90	380000	760000	180	350	305	464	640	560			365	360	20	M24	1000	11
100	500000	1000000	220	390	330	512	690	612			390	400	24	M24	1000	12

¹⁾ Required space to align the coupling or replace the sealing ring, respectively.

²⁾ Grease feeding for each coupling half

Order form:	GEARex® FH 10	d ₁ Ø 50	d ₂ Ø 50	250
	Size and type of coupling	Finish bore keyway DIN 6885 sheet 1	Finish bore keyway DIN 6885 sheet 1	Shaft distance dimension E _H

Displacements

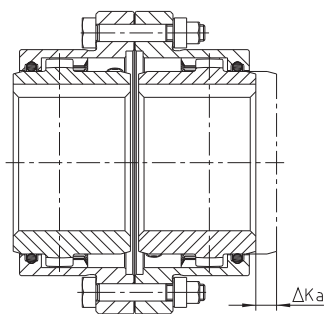

Axial displacement

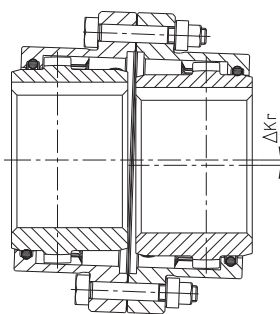

Radial displacement

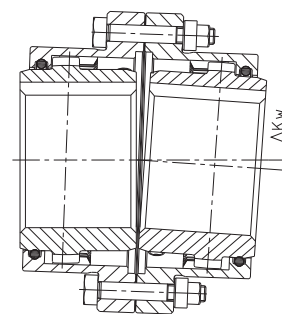

Angular displacement

Displacements			
Size	Max. axial displacement ΔKa [mm]	Max. permissible displacements ¹⁾	
		ΔKr [mm]	ΔKw [°]
10		± 0,4	
15		± 0,5	
20		± 0,6	
25	± 1,0	± 0,8	
30		± 1,0	
35		± 1,0	
40		± 1,2	
45		± 1,4	
50		± 1,6	0,5° each hub
55	± 1,5	± 1,8	
60		± 2,0	
70		± 2,2	
80		± 2,5	
85		± 2,8	
90	± 2,0	± 3,0	
100		± 3,2	

1) The displacement figures are maximum figures which must not arise at the same time. If both radial and angular displacement arise at the same time, these figures have to be reduced (see examples of calculation and diagramme).

Example 1:

ΔKr = 30%

ΔKw = 70%

Example 2:

ΔKr = 60%

ΔKw = 40%

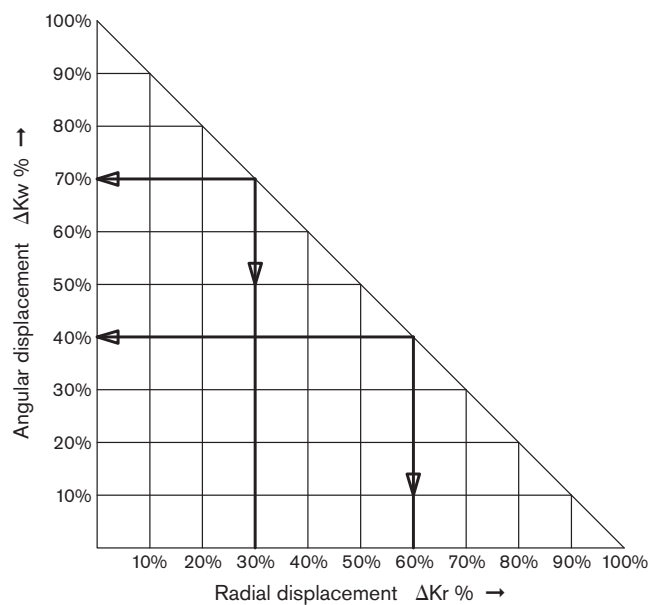

Flange dimensions

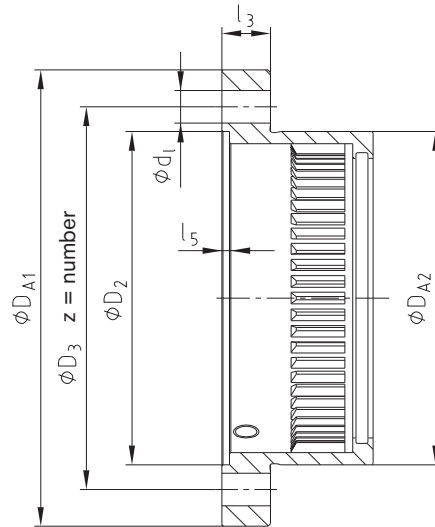

Flange dimensions								
Size	Dimensions [mm]							
	D_{A1}	D_{A2}	D_2	D_3	d_1	number z	l_3	l_5
10	111	84	82	95,25	6,35	6	14	3
15	152	107	105	122,24	9,52	8	19	3
20	178	130	130	149,23	12,70	6	19	3
25	213	158	153	180,97	15,87	6	22	4
30	240	182	178	206,38	15,87	8	22	4
35	280	214	205	241,30	19,05	8	28,5	5
40	318	250	243	279,40	19,05	8	28,5	4
45	347	274	265	304,80	19,05	10	28,5	5,5
50	390	309	302	342,90	22,22	8	38	6
55	425,5	334	320	368,30	22,22	14	38	6
60	457	365,5	353	400,05	22,22	14	26	6
70	527	425	412	463,55	25,40	16	28,5	8

Other types

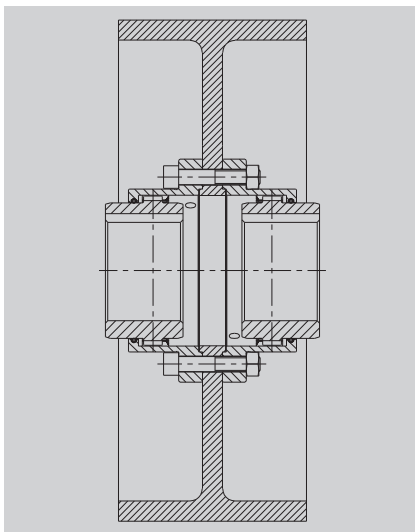

**Type with
brake drum**

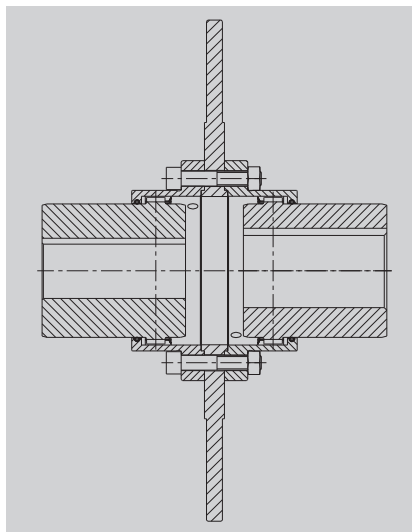

**Type with
brake disc**

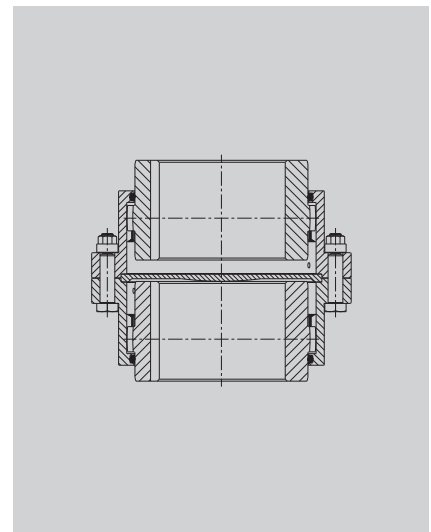

**Type VD
(vertical mounting)**

