

MINEX®-S
Magnetic couplings

Made for Motion



Table of contents



MINEX®-S	
Magnetic coupling	169
Coupling description	171
Technical description	172
Sizes SA 22/4 to SB 60/8	173
Sizes SA 75/10 to SF 250/38	174
Sizes SA 110/16 to SE 200/30 with stationary can from ceramics	176
Mounting sets and customized assemblies	177

Coupling description

General description

The MINEX®-S is a permanent-magnetic synchronous coupling that transmits torque through magnetic forces between the internal and the external rotor.

It ensures a hermetic separation of the drive and the driven side in its main function as sealing element in pumps and agitators. For critical media like aggressive acids etc. it serves as a reliable seal and prevents serious leakages occurring.

On request KTR can manufacture special customer-specific types of the MINEX®-S in connection with KTR hydraulic components. Thus existing pumps with a conventional shaft seal can be easily retrofitted with the MINEX®-S.



Function/Design

Torque transmission

The coupling consists of an external and an internal rotor. The external rotor has high-quality, permanent magnets of changing polarity on the inner side and the internal rotor has them on the outside. The external rotor is normally fixed on the drive side and the magnets are glued in the keyways. The magnets of the driven-sided internal rotor are cylindrically ground to ensure a minimal air gap and encapsulated through a magnetic cover that is impervious to fluids.

In their non-operative states the north and south poles of the rotors are opposite to each other and the magnetic field is completely symmetric. It is only when the rotors are twisted that the magnetic field lines are moved, hence the torque is transmitted through the air gap. Then there is a synchronous operation under a constant torsion angle.

If the maximum coupling torque and the maximum torsion angle are exceeded, the power transmission is interrupted. Thus the MINEX®-S offers an overload protection function of the drive train. After removing the cause of the overload (e. g. damage to the bearing, blocking of the internal rotor) both rotors can be synchronised again and operation is resumed.

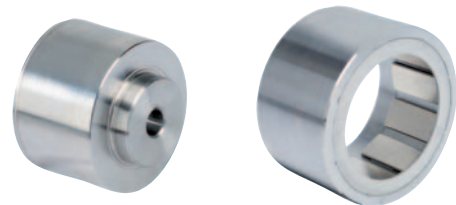

Internal rotor

External rotor

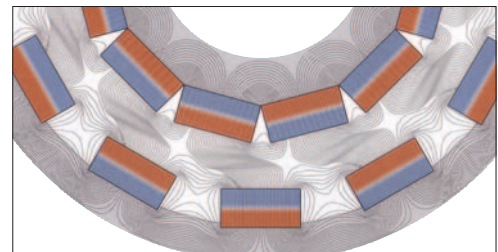

Run of flux lines

Sealing function

The main component of the MINEX®-S is the containment shroud that is fixed to the driven-sided power unit and separates internal and external rotor from each other. It ensures a low-vibration torque transmission working without mechanical connection and guarantees a completely leak-proof separation of product and atmosphere. The sealing is achieved with a flat seal or an o-ring, thus eliminating the need to dynamically load the sealing elements.

The containment shroud and internal rotor are generally made from stainless steel 1.4571 or Hastelloy. The magnets of the internal rotor are encapsulated to make them impervious to fluids and thus protected against external influences.

Since the containment shroud is a stationary component with a rotating magnetic field, it causes losses of eddy current. In order to keep these low, the containment shroud is also available in Hastelloy from size 75 upwards ensuring a higher electrical resistance than stainless steel. If eddy current losses can definitely be excluded, alternative materials like PEEK or ceramics may be chose.



Containment shroud

Technical description

Explosion-protection use

MINEX®-S couplings are suitable for the power transmission in drives that are used in hazardous areas. As a component of the device class II the couplings are assessed and confirmed for the use in explosive areas of category 2G according to the EU standards 94/9/EC (ATEX 95).



Please see our website www.ktr.com for advice, copies of certification and operating/mounting instructions.

Technical data																
Size	Stat. tear torque T_{Kmax} with 20 °C [Nm]	External rotor					Internal rotor					Containment shroud				
		Standard material		Max. operating-temperature t_{max} [°C]	Weight unbores [kg]	Mass moment of inertia with min. bore Ø [kgm²]	Standard material		Max. operating-temperature t_{max} [°C]	Weight pilot bored [kg]	Mass moment of inertia with min. bore Ø [kgm²]	Standard material ²⁾		Max. pressure resistance P_N/P_{max} ¹⁾ [bar]	Max. operational speed [rpm]	
		Hub	Magnets				Hub	Magnets				Flange	Can			
SA 22/4	0,15			150	0,129	$30,01 \times 10^{-6}$	1.4462	NdFeB	150	0,039	$1,912 \times 10^{-6}$			60/90		
SA 34/10	1		NdFeB		0,256	$117,4 \times 10^{-6}$				0,093	$12,1 \times 10^{-6}$		Stainless steel 1.4571	16/24		
SA 46/6	3				0,619	$458,6 \times 10^{-6}$				0,317	125×10^{-6}					
SA 60/8	7				1,751	2279×10^{-6}				0,563	221×10^{-6}					
SB 60/8	14				2,682	3759×10^{-6}				0,932	380×10^{-6}			40/60		
SA 75/10	10		Samarium-cobalt (Sm_2Co_{17}) or neodymium-iron-boron (NdFeB)	300 °C (Sm_2Co_{17}) or 150 °C (NdFeB)	1,362	3159×10^{-6}				0,940	539×10^{-6}		Stainless steel 1.4571	Stainless steel 1.4571 or Hastelloy	16/24 bar with 1.4571, 25/375 bar with Hastelloy	3600 rpm using metal stationary cans as per KTR standard
SB 75/10	24	2,095			4829×10^{-6}			1,494	889×10^{-6}							
SC 75/10	40	2,889			6654×10^{-6}			1,893	1232×10^{-6}							
SA 110/16	25	1,841			7356×10^{-6}			2,550	3264×10^{-6}							
SB 110/16	60	2,822			12111×10^{-6}			3,732	5229×10^{-6}							
SC 110/16	95	3,788			16238×10^{-6}			4,845	7137×10^{-6}							
SB 135/20	100	3,747			22878×10^{-6}			5,668	12333×10^{-6}							
SC 135/20	145	4,904			29874×10^{-6}			7,362	16768×10^{-6}							
SD 135/20	200	6,061			36870×10^{-6}			9,497	22387×10^{-6}							
SC 165/24	210	5,305			45480×10^{-6}			11,400	37917×10^{-6}							
SD 165/24	280	6,559	56170×10^{-6}			14,674	50633×10^{-6}									
SE 165/24	370	7,813	66860×10^{-6}			17,303	60855×10^{-6}									
SD 200/30	430	9,887	117296×10^{-6}			26,057	125915×10^{-6}									
SE 200/30	550	10,364	122342×10^{-6}			26,114	126405×10^{-6}									
SD 250/38	670	10,930	202540×10^{-6}			37,920	282795×10^{-6}									
SE 250/38	820	13,030	241273×10^{-6}			45,220	340420×10^{-6}									
SF 250/38	1000	15,130	280000×10^{-6}			52,500	397915×10^{-6}									

- Resistances to higher pressures can be realized on request of the customer.
- Alternative materials of stationary cans like oxide ceramics (see page 176) or PEEK are available on request.

Description	Reference	Definition or explanation
Static tear torque of coupling	T_{Kmax}	Max. transmittable torque, from which onwards the magnetic forces tear during the static test.

Description	Reference	Definition or explanation
Maximum operating temperature	t_{max}	Max. permissible temperature causing a temporary attenuation of the magnetic field. Exceeding irretrievable losses of magnetization.

Torque reduction with temperature increase

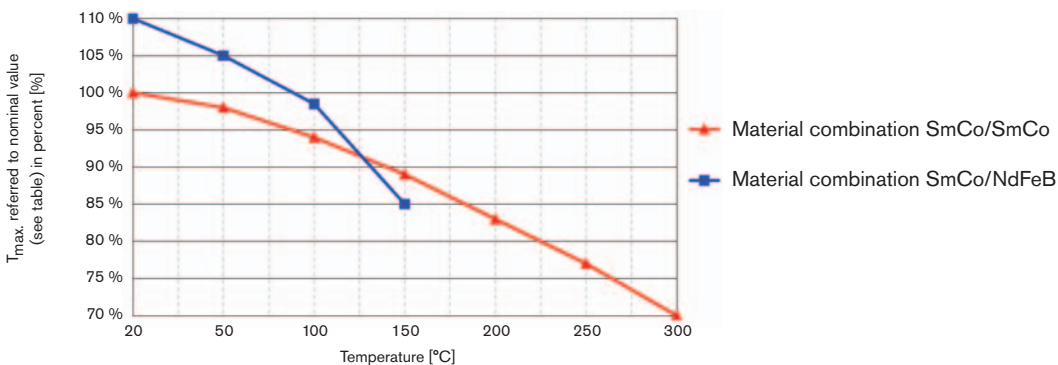

Temporary torque reduction with increased temperature for alternative material combinations [%]

Please note:

To reduce expenses KTR would recommend to use NdFeB magnets for the external rotor if the operating temperature falls below 150 °C.

Sizes SA 22/4 to SB 60/8

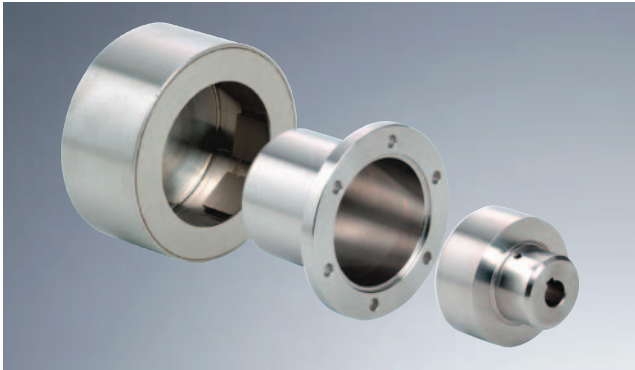

- Contactless torque transmission
- Hermetic separation of drive and driven side
- Available from stock with pilot bored internal rotor and unbored external rotor
- Finish bore possible to ISO H7, feather keyway to DIN 6885 sheet 1 - JS9
- Standard containment shroud made from stainless steel 1.4571
- Approved according to EC Standard 94/9/EC (Explosion Certificate ATEX 95)
- Mounting instructions available at www.ktr.com

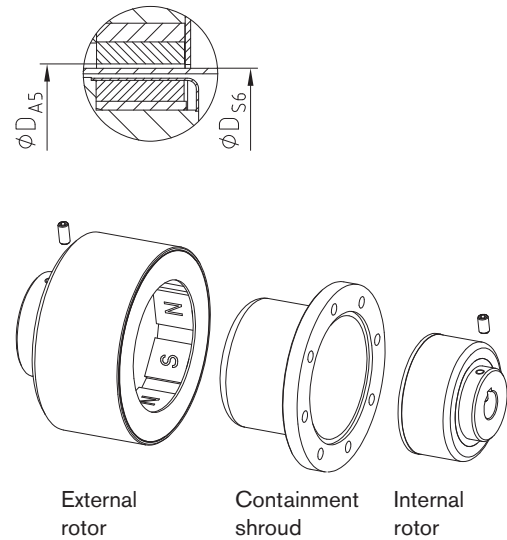
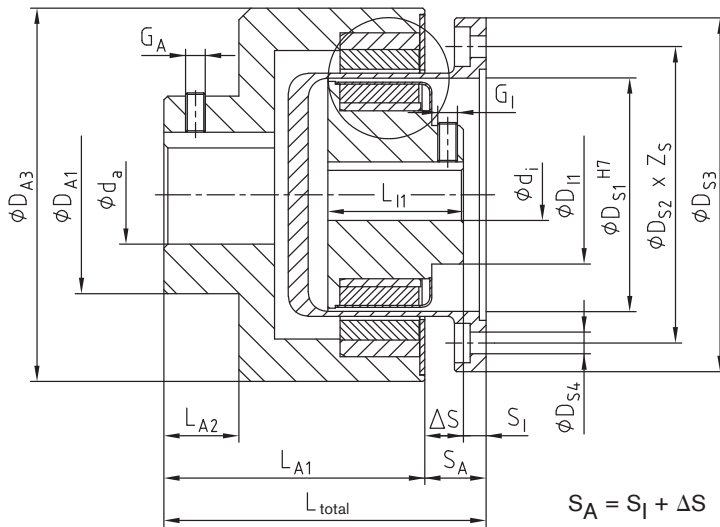

Technical data – Internal rotor and containment shroud														
Size	T_{Kmax} [Nm] in case of ~ 20 °C	Dimensions [mm]												
		Internal rotor						Containment shroud						
		Finish bore ¹⁾ d_i		D_{I1}	L_{I1}	S_I		G_I	D_{S1}	D_{S2}	D_{S3}	D_{S4}	Z_S	
min.	max.	min.	max.											
SA 22/4	0,15	5	9	20	20	2,0	2,0	M3	21,5	38	46	4,5	8	
SA 34/10	1	5	12	20	22	2,0	5,5	M3	34	46	55	4,5	4	
SA 46/6	3	8	16	28	33	6,5	7,0	M4	46	–	78	–	–	
SA 60/8	7	12	22	36	36	2,2	3,5	M5	59	75	89,5	5,5	8	
SB 60/8	14	–	–	–	56	0,0	3,5	–	–	–	–	–	–	

Technical data – External rotor and general														
Size	Dimensions [mm]													
	External rotor							General						
	Finish bore ¹⁾ d_a		D_{A1}	D_{A3}	L_{A1}	L_{A2}	ΔS	G_A	D_{S6}	D_{A5}	L_{total}			
min.	max.	min.									max.			
SA 22/4	5	11	18	38	35	8,5	5,0	M4	23,5	24,8	42	42		
SA 34/10	5	14	22	53	38,5	10,5	5,5	M4	36,0	37,3	46	49,5		
SA 46/6	5	19	30	69,5	53	16	9,0	M5	48,5	49,4	68,5	69,5		
SA 60/8	9	28	50	94,5	66	19	12,0	M6	61,0	63,2	80	81,3		
SB 60/8	9	38	–	–	93	15	–	M8	61,5	63,2	105	108		

1) Bore H7 with feather keyway DIN 6885 sheet 1 [JS9]

Order form:	MINEX® SA 60/8	Design	d_i Ø 20 mm	d_a Ø 24 mm
	Coupling size	NdFeB – $t_{max.} = 150$ °C Sm ₂ Co ₁₇ – $t_{max.} = 300$ °C	Finish bore (H7) feather keyway DIN 6885 sheet 1 (JS9)	

Sizes SA 75/10 to SF 250/38

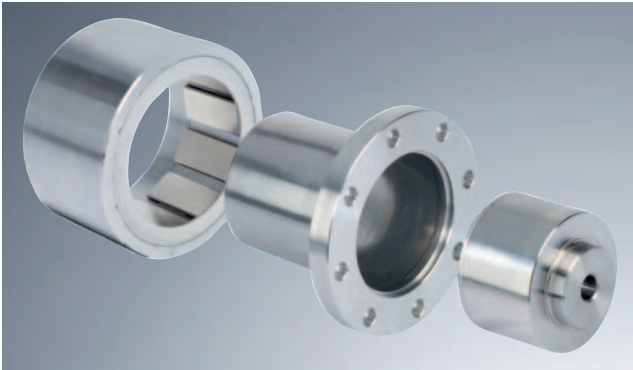

- Contactless torque transmission
- Hermetic separation of drive and driven side
- Two-part external rotor with flange hub that must be separately screwed, customer-specific variations are possible
- Available from stock with pilot bored internal rotor
- Finish bore possible to ISO H7, feather keyway to DIN 6885 sheet 1 - JS9
- Containment shroud also available from stainless steel or Hastelloy
- Approved according to EC Standard 94/9/EC (Explosion Certificate ATEX 95)

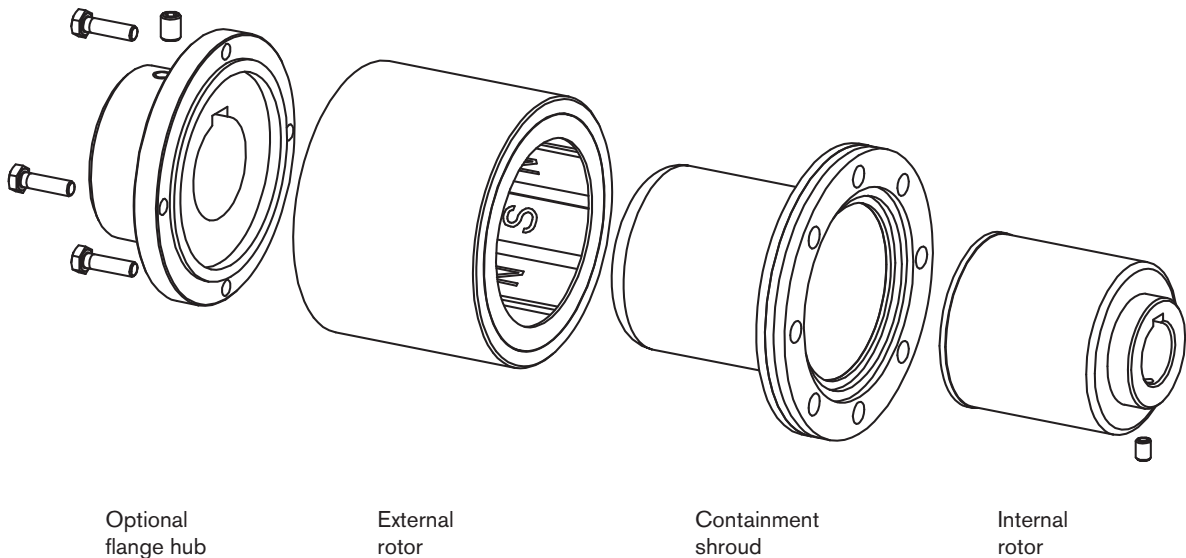
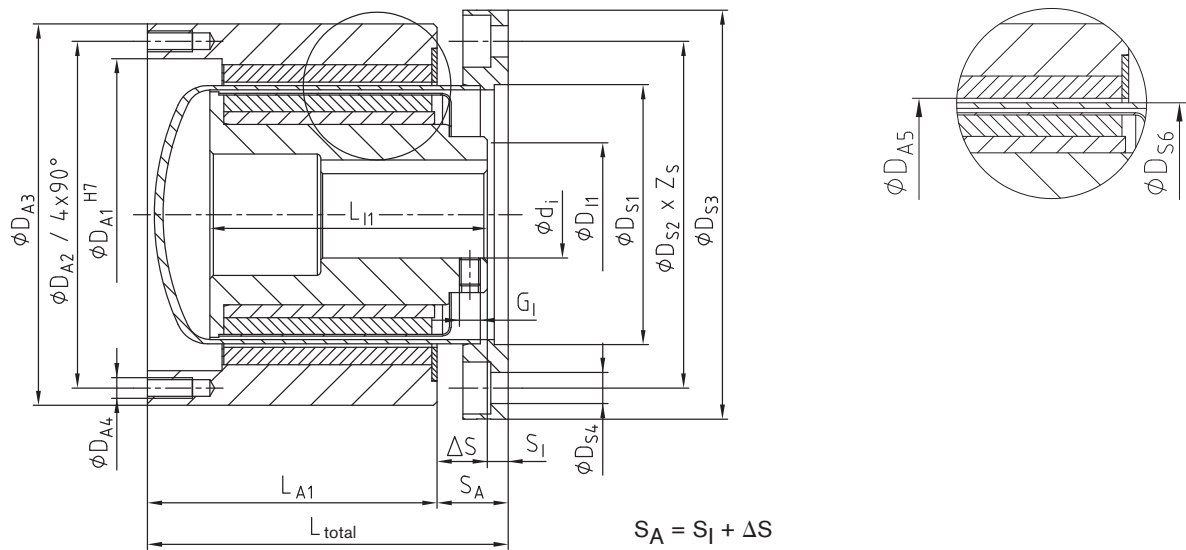

Order form:	MINEX® SB 75/10	Design	$d_i \text{ } \varnothing 20 \text{ mm}$	$d_a \text{ } \varnothing 24 \text{ mm}$	Containment shroud type
	Coupling size	NdFeB - $t_{\text{max.}} = 150 \text{ }^\circ\text{C}$ Sm ₂ Co ₁₇ - $t_{\text{max.}} = 300 \text{ }^\circ\text{C}$	Finish bore (H7), feather keyway DIN 6885 sheet 1 (JS9)		Stainless steel 1.4571 or Hastelloy

Technical data – Sizes SA 75/10 to SF 250/38

Technical data – Internal rotor and containment shroud													
Size	T _{Kmax.} [Nm] in case of ~ 20 °C	Dimensions [mm]											
		Internal rotor						Containment shroud					
		Finish bore ¹⁾ d _i		D _{I1}	L _{I1}	S _I		G _I	D _{S1}	D _{S2}	D _{S3}	D _{S4}	Z _S
		min.	max.			min.	max.						
SA 75/10	10				39,5		46,5						
SB 75/10	24	12	28	45	58	4	26,5	M6	75	100	118	9	8
SC 75/10	40				80		6,0						
SA 110/16	25				45		51,0						
SB 110/16	60	14	55	72	65	4	31,0	M8	110	133	153	9	12
SC 110/16	95				85		11,0						
SB 135/20	100				65		46,5						
SC 135/20	145	20	70	90	85	4	26,5	M10	135	158	178	9	16
SD 135/20	200				110		7,0						
SC 165/24	210				85		66,5						
SD 165/24	280	24	90	110	110	6	41,0	M12	163,5	192	218	11	12
SE 165/24	370				130		22,0						
SD 200/30	430				135		18,0	M16	200	252	278	11	12
SE 200/30	550	38	90	130	135	6	18,0	M16	200	252	278	11	12
SD 250/38	670				115		7,0						
SE 250/38	820	38	90	165	135	–	26,0	M16	255	285	315	13,5	12
SF 250/38	1000				155		46,0						

Technical data – External rotor and general									
Size	Dimensions [mm]								
	External rotor						General		
	D _{A1}	D _{A2}	D _{A3}	D _{A4}	L _{A1}	ΔS	D _{S6}	D _{A5}	L _{total}
SA 75/10					41				
SB 75/10	90	100	110	M6	61	12,5	74,6	76,4	102
SC 75/10					83,5	14,5			
SA 110/16					41				
SB 110/16	126	135	145	M6	61	19,0	111,5	113,1	115
SC 110/16					81				
SB 135/20					70				
SC 135/20	150	160	170	M6	90	18,5	136,5	138,5	139
SD 135/20					110	22,0			
SC 165/24					90	18,5			
SD 165/24	180	188	198	M6	110	21,0	167,0	169,2	170
SE 165/24					130				
SD 200/30					130	26,0	198,0	199,5	180
SE 200/30	212	222	232	M6	130	26,0	198,0	199,5	180
SD 250/38					110				
SE 250/38	267	277	287	M6	130	26,0	253,0	255,0	183
SF 250/38					150				

1) Bore H7 with feather keyway DIN 6885 sheet 1 [JS9]

Futher sizes on request.

Sizes SA 110/16 to SE 200/30 with stationary can from ceramics

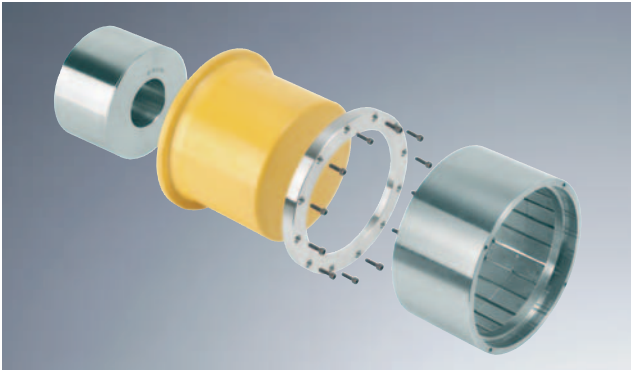

- No eddy current losses due to stationary can from ceramics
- No heat accumulation in the coupling caused by the stationary can
- Usually internal cooling measures are not necessary
- Suitable for dry running drives like compressors, vacuum pumps, etc.
- The selection torque may be reduced by 10 - 15 %
- Internal and external rotor in accordance with KTR standard
- Sizes SA 110/16 to SE 200/30 available from stock, other sizes on request
- Approved according to EC Standard 94/9/EC (Explosion Certificate ATEX 95)

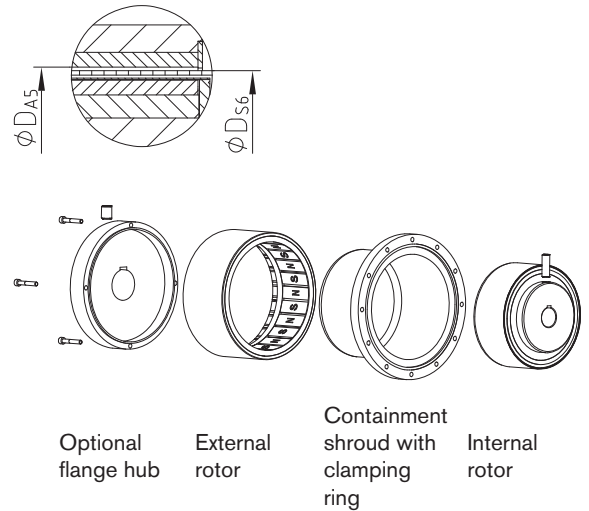
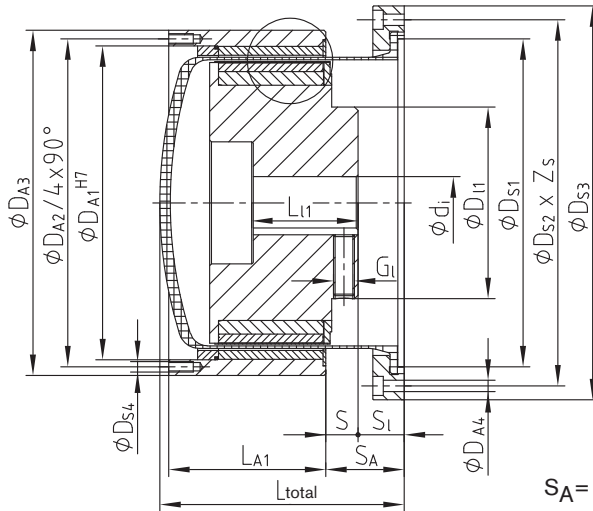

Technical data – Internal rotor and containment shroud													
Size	T _{Kmax.} [Nm] in case of ~ 20 °C	Dimensions [mm]											
		Internal rotor						Containment shroud					
		Finish bore ¹⁾ d _i		D _{I1}	L _{I1}	S _I		G _I	D _{S1}	D _{S2}	D _{S3}	D _{S4}	Z _S
min.	max.	min.	max.										
SA 110/16	25				45								
SB 110/16	60	14	55	72	65	4,0	49,0	M8	119,5	148	162	5,5	12
SC 110/16	95				85		9,0						
SB 135/20	100				65		46,5						
SC 135/20	145	20	70	90	85	4,0	26,5	M10	145	173	187	5,5	12
SD 135/20	200				110		7,0						
SC 165/24	210				85	3,5	28,0						
SD 165/24	280	24	90	110	110	–	4,0	M12	188	210	226	6,6	12
SE 165/24	370				130	6,0	14,0						
SD 200/30	430												
SE 200/30	550	38	90	130	135	6,0	14,0	M16	242	272	294	9,0	12

Technical data – External rotor and general										
Size	Dimensions [mm]									
	External rotor						General			
	D _{A1}	D _{A2}	D _{A3}	D _{A4}	L _{A1}	ΔS	D _{S6}	D _{A5}	L _{total}	
SA 110/16					41					
SB 110/16	126	135	145	M6	61	19,0	111,5	113,1	115	
SC 110/16					81					
SB 135/20					70					
SC 135/20	150	160	170	M6	90	18,5	136,5	138,5	139	
SD 135/20					110	22,0				
SC 165/24					90	18,5				
SD 165/24	180	188	198	M6	110	21,0	167,0	169,2	170	
SE 165/24					130					
SD 200/30										
SE 200/30	212	222	232	M6	130	26,0	198,0	199,5	180	

1) Bore H7 with feather keyway DIN 6885 sheet 1 [JS9]

Order form:	MINEX® SB 135/20	Design	d _i Ø 20 mm	Containment shroud type
	Coupling size	NdFeB – t _{max.} = 150 °C Sm ₂ Co ₁₇ – t _{max.} = 300 °C	Finish bore (H7), feather keyway DIN 6885 sheet 1 (JS9)	Oxide ceramics ZrO ₂ MgO

Mounting sets and customized assemblies

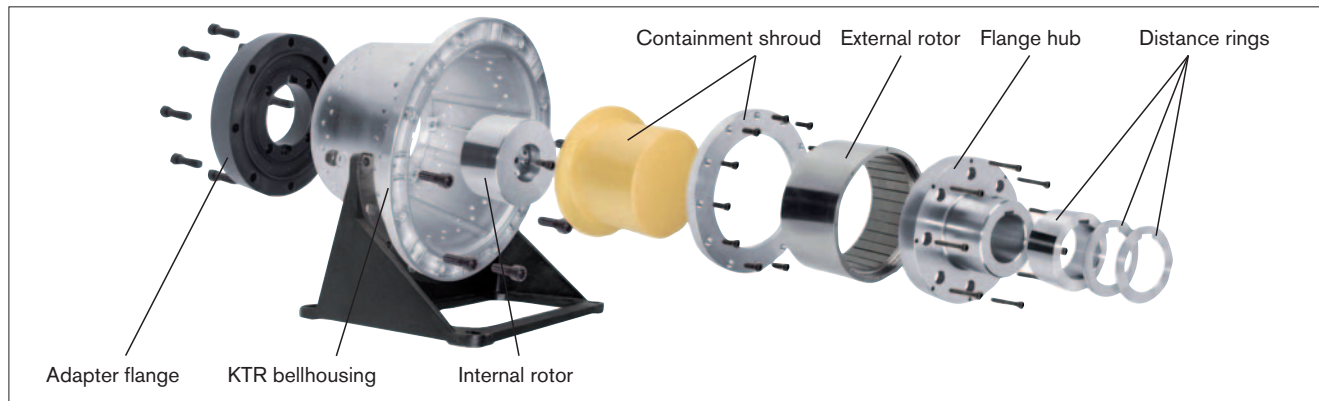

On request KTR can offer special customer-specific solutions in combination with hydraulic components from KTR, whereby existing systems can be easily retrofitted with the MINEX®-S.

Redesigning sets for PUR foaming processes

Conveying and proportioning the media polyol and isocyanate in the processing plants for PUR, ambient air has to be prevented from penetrating into the process, since otherwise unwanted reactions may be produced.

For a reliable sealing of such drives KTR offers standard sets for retrofitting, among others for axial piston pumps types **REXROTH A2VK** and **ROTARY POWER C series** offering the following benefits:

- Maintenance-free operation
- Standstill periods are considerably reduced
- No more problems with sealing
- Better efficiency and process safety

The assemblies are available for all motor-pump-combinations and in various materials.



Axial piston pump REXROTH type A2VK



Maintenance-free sealing of dosing pump for polyde and isocyanate in high-pressure reaction casting machines

Examples of application

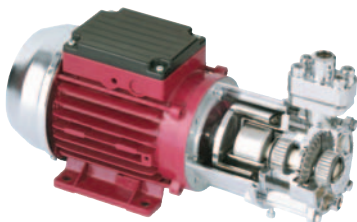

Use of the MINEX®-S in a small centrifugal pumps

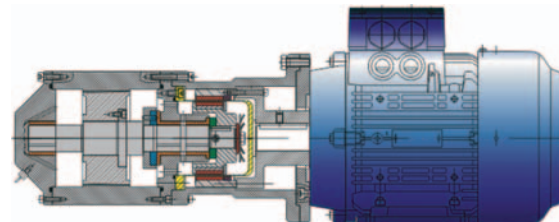

MINEX®-S for sealing homogenizers for heavy oil processing in marine operation



Re-equipment of a gear pump with MINEX® SA 75/10, bellhousing PK 200/30, base flange and damping rod

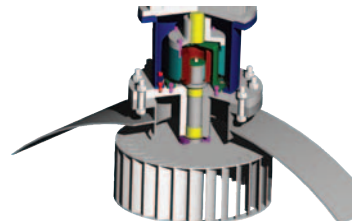

MINEX®-S for the separation of autoclaves (T.B.M./STERICHEM) in laboratories and clinics

Technical data for coupling selection/selection of components

Motor type	_____	Pump type	_____
Power	_____ kW	Speed	_____ rpm
Pressure	_____ bar	Temperature	_____ °C
Viscosity of medium	_____ mm ² /s	Max. perm. dimensions	_____ ØDxL _{total}

